

**From:** Jerry Craig - Editor <newsletter@stlcorvette.club>

**To:** email2jwc <email2jwc@aol.com>

**Subject:** May 2017 Newsletter. Meeting Tuesday May 2 - 7PM at Grand Slam

**Date:** Thu, Apr 27, 2017 3:39 pm

---

Welcome

Birthdays and Anniversaries

President's Message

April Meeting Minutes

New Events

Corvette Museum Report

April Events

Articles

**Sponsored by ELCO Chevrolet**

[View this email in your browser](#)



### May Birthdays and Anniversaries

#### Birthdays

Vickie DeBruin	May 13
Conita Shoulders	May 19
Pat Cox	May 20
Deb Waslster	May 23
Anne Pickles	May 25
Chris Woods	May 26
Sandy Kirby	May 29

#### Anniversaries

Terry & Deb Walster	May 4
Bob & Janice Kerin	May 17
Stephen and Leanne Lyle	May 24
Jerry & Sonja Giffon	May 25
Steve & Ingrid Ward	May 26

Pam Queen      May 30

Mark Gerecke      May 31

---

## President's Message

April 21, 2017

Spring is definitely teasing us. We've had some 90 degree days and some below 40 degree days.

Personally I like the warm a lot better than the cold but we certainly can't complain much about this winter.

I can't recall a winter that I have been able to drive my Corvette as often as I have this year.

Once again your club has been active in April. On the 2<sup>nd</sup> a few of us attended Cars and Coffee at

Gateway Motor Sports Park. This was a great event with lots of interesting cars to see. On the 8<sup>th</sup> we had

the annual clean up at Jefferson Barracks with a great turnout to help with the work. Thanks Marty, Judy,

Karen and Mike for Sponsoring. On the same date members attended The Cause for Paws event

sponsored by the Marlos and Grubbs. It was a great evening for a good cause. On the 19<sup>th</sup> we had a great

turnout for the Retiree's lunch, we do like to go to lunch!!!! Thanks Ron and Mary Ann the location was

---

great as was the food. Don't forget the Bash is next week at the museum and the Murrays and Tidwell's are sponsoring a happy hour the 28th at Pub 231, where we had our car show last year. Sunday the 30<sup>th</sup> is the Cruise-In for St Judes and don't forget Fritz's ice cream at 6 PM. Watch your e mail for all upcoming events. If you have not yet signed up for the Route 66 event there are still some rooms left. For more info refer to the e mail Bob sent out on the 21<sup>st</sup>. Corvette Adventures at Chula Vista is coming up in June, we have about 14 cars going I believe and you still have time to sign up. Contact Steve Kirby for info or go to their web site to sign up.

Just a few housekeeping details, please make sure Mike Grubb is aware of any events before scheduling. The purpose of this is to avoid scheduling conflicts. Please remember name badges at meetings, it helps our new members get to know everyone.

Well I think that's about it for now, see you at the next meeting, Tuesday May 2<sup>nd</sup>. The meeting will start at 7 PM with Dinner from 5:30 on.

Save The Wave

Ray and Mike



## April Meeting Minutes

The St. Louis Corvette Club met at Grand Slam Bar and Grill in Fenton for the monthly meeting on April 4, 2017.

The meeting was called to order by President Ray Queen at 7:00 pm and the Pledge of Allegiance was recited.

The Introduction of Officers is as follows: President- Ray Queen, Vice President- Mike Grubb (absent), Secretary- Ron Hagenow, Treasurer- Don Pickles, Sergeant at Arms- Michelle Finn and Membership- Judy Giovanoni. Our sponsors Eric DeBruin and Mark Gerecke were also present.

Ray reminded everyone about the sign in sheet, 50/50 tickets, and attendance prize. He welcomed Michelle Finn back from her recent illness.

We had Amy Donnelly and daughter Caroline as guests of Randy and Ruth Howard.

---

Ray asked for a motion to approve the March minutes. Jeff Craig made the motion that they be approved and it was seconded by Ken Payne. The motion passed.

Judy Giovanoni gave the membership report. We currently have 96 regular members, 18 associate members, 3 lifetime members and 4 sponsors for a total of 121. Judy also announced the April birthdays and anniversaries.

Don Pickles presented the treasurer report. Steve Kirby made a motion to approve the report and it was seconded by Judy Dooley. The motion passed.

Judy Dooley gave the NCM Ambassador's report. The latest club banner that was displayed at the museum was behind the officer's table. They are raffling off the banner with chances of \$5 per ticket. They also have tickets for the latest \$10 raffle car, a red convertible. Marty is still collecting Hot Wheel cars for the museum and recently took several hundred down to them. Also remember the Bash is coming up the end of the month. Sponsorships are

---

available at the go kart track for \$1000. Also members of the museum are now eligible for the GM employee discount if you purchase a new car.

Jeff Craig gave the NCCC Governor's report. Competition season is starting. An upcoming autocross at Rantoul has been cancelled. If you go to the Bash there will be a high speed event on the track with instructors if you want to go fast.

Jerry Craig said the newsletter was on target. He gets a report that only 65% ever opened up the newsletter.

Steve Kirby reported the website was on target.

Jerry Craig reported the historical committee is on target.

Mark and Eric reported that ELCO has sold the remaining 2016 car with \$19,000 off of sticker. Orders for 2017 will be ending soon.

---



Under Committees, Marty Dooley reported that several members recently set up the fountains at the VA garden. He also reminded everyone of the upcoming clean-up day this Saturday. Chris Woods reported on the Christmas party at Royale Orleans. She reviewed the menu and bar options. We have an option for \$2 more for a fish entrée but no one wanted it. The cost is \$25 with a cash bar or \$35 with an open bar. Ballots were handed out for everyone to vote on what they wanted. The results were we will pay \$25 each with a cash bar.

Ron Hagenow, in the place of Vice President Mike Grubb, reviewed the previous and upcoming events. They are:

Previous:

March 11 – Annual Shooting Event sponsored by Tom Marlo. Lunch afterwards at Hooters. There were about 7 shooters and everyone enjoyed lunch afterwards.

---

March 15 – Monthly Retiree's Lunch at Papa Vito's in Millstadt. Thanks to the Zeissets for setting it up. Food was great and there were about 25 people who attended.

March 25 – Little Egypt Car Rally sponsored by Jeff and Patty Craig. The weather was bad and only a few cars attended. Peggy Craig and Meg (aka Thelma and Louise) attended.

March 26 – First Fritz's run sponsored by Peggy Craig. There were about 7 cars there.

Upcoming:

April 8 – VA garden cleanup sponsored by Dooleys and Prices

April 8 – Cause for Paws Charity Event sponsored by Marlos

April 19 – Monthly retiree's lunch sponsored by Hagenows

April 28 – A new event by the Murrays and Tidwells for a Happy Hour at Pub 231, where we had our car show last year. Meet about 5:00 pm.

April 30 – Fritz's sponsored by Peggy Craig

May 2 – Monthly meeting

---

May 17 – Mystery retiree's lunch sponsored by Rick Frierdich

Also Bob Kusky spoke about the upcoming trip he has planned in July.

Thank you to the Mattlers for bringing the cake. Next month the cake will be brought by the Tidwells.

Michelle Finn spoke about her recent surgery and the problems she has encountered in recovering. She thanked the membership for the many cards and well wishes she received.

The 50/50 winner was Pam Queen for \$77.00

There were 51 members in attendance.

Jan Murray won the door prize. Attendance prizes were won by Carl Cox, Sue Berard, Kurt Sheer, Ray Queen and Gary Murray.

---

The next meeting will be on May 2, 2017 at 7:00 pm.

Judy Dooley made a motion that the meeting be adjourned and it was seconded by Chris Woods. The motion passed and the meeting adjourned at 8:00 pm.



Thank you for attending. Drive Safely, Save the Wave and always have fun!

Respectfully Submitted by Ron Hagenow - Secretary

---

**May Events - See Website <http://stlcorvette.club> (no www)**

---

**St. Louis Corvette Club**Today   Sunday, April 30 ▾ Print [Week](#) [Month](#) [Agenda](#) ▾**Sunday, April 30**12:00pm [Cruise-in for St. Judes](#)6:00pm [Fritzs' Ice Cream Run](#)**Tuesday, May 2**7:00pm [STLCC meeting](#)**Sunday, May 7**9:00am [VA planting day](#)**Saturday, May 13**11:00am [River to River All Corvette Car Show](#)**Wednesday, May 17**11:15am [Retiree's luncheon](#)**Thursday, May 18**[C4 Gathering](#)**Friday, May 19**[C4 Gathering](#)**Saturday, May 20**[C4 Gathering](#)**Sunday, May 21**11:00am [V.A. Garden planting](#)**Sunday, May 28**

Events shown in time zone: Central Time

 Google Calendar

## Hot Link to Website for Full Calendar

---



**Pub 231**  
**6070 Telegraph Road**  
**Friday April 28**  
**5:00 PM til ??**

*Happy Hour Friday April 28*

*For those of you who missed the meeting we are passing an item on for your calendar.*

*Remember Pub 231 - Where we had the car show last August? It is located at 6070 Telegraph Road. We had such a great time at the car show we plan to have the car show there again this coming August.*

*AND.....since Julie the owner was so accommodating to us and all she did for the car show, in addition to the sizeable donation she made to the Fisher House that day.....The Murray's and the Tidwell's are hosting a HAPPY HOUR there on Friday, April 28th. Please join us. We Plan to begin our Happy Hour/Evening at 5:00. The Murray's will be there a bit earlier in case some of you want to beat the Friday night traffic. Also, at 7:30pm Pub 231 has an added attraction of live music provided by Greg Manis (From what we understand this is similar to Winery Music) and some Rock and Roll.*

*It's the end of April so the weather should be wonderful for taking those Corvettes out for a Friday Night Happy Hour and Live Music. Parking is not a problem, the lot is huge. Julie has a TV over the bar sporting pictures of our club car show as well as a special feature of our own Carl Cox's photo op with the Shock Top Girls.*

*If possible we would like to give Julie an idea of how many people she should set up for - so - if you could let Debbie/Gary or Jan/Gary know you would like to attend that would be great but if you decide to join us at the last minute that will be fine too. If you have any questions, need directions and want to give us a ball park idea if you will be joining us just let us know at [yesssvett@yahoo.com](mailto:yesssvett@yahoo.com) or [debbie-tidwell@sbcglobal.net](mailto:debbie-tidwell@sbcglobal.net).*

*Thanks - Hope to see you there!*

---







### The V.A. Garden Spring Cleaning

Our St. Louis Corvette Club has stepped-up yet again this year with our spring cleaning and planting in the garden at Building 52 - Veterans Hospital At Jefferson Barracks. This spring we had two days and we had great volunteers show up to help continue making a great garden area for our rehabbing Veterans.

This is something our club started about 11 years ago as a way of giving back. The garden looks great again thanks to all who helped, and let's not forget all the donations we all made to help our cause in the garden.

**Note: May planting dates cancelled.**  
**Warm weather allowed us to plant early.**

Marty and Judy Dooley

---

# May Retiree Luncheon

Wednesday May 17, 2017

(Mystery Destination)

Meet at 11:15 am @ Quick Trip on NW side of  
Hwy 21 Just South of Butler Hill Rd.

We will depart about 11:30 am

We'll drive about 30 minutes to our destination.

Please Bring Your radios and your appetite.

---

### **Ambassador report. May Newsletter**

The IT team has been hard at work fine tuning a new member only section of the NCM website. This area will allow members to view their personal information, donations, registrations, member specific information and links, and you will even be able to reprint your membership card, if needed, and see when your renewal date is (if applicable) and even when you joined the NCM.

You can also receive discounts on hotels and car rentals through:

[www.alumnibenefits.org/corvette](http://www.alumnibenefits.org/corvette)

These include:

Car Rentals - Alamo, Budget,  
National, Avis, & Hertz.

Hotels - Hotel Bargain, Wyndham, & Choice properties.

Lifetime members also receive additional benefits of reciprocal programs including the North American Reciprocal museum group (AMG).

Judy Dooley  
NCM Ambassador

*Just a reminder that if you have found any Hotwheels Corvettes for the National Corvette Museum, please bring them to the meeting on Tuesday, May 2 as Marty and Judy will soon be making a run to NCM to drop them off.*

---

## **April Events**

**Retired and Everyone Welcome Lunch**



## Articles and Notes

From: Bob Kusky <[BKusky@uspaint.com](mailto:BKusky@uspaint.com)>  
To: Jerry Craig ([email2jwc@aol.com](mailto:email2jwc@aol.com)) <[email2jwc@aol.com](mailto:email2jwc@aol.com)>  
Subject: C5 Service Lock Issue  
Date: Fri, Mar 31, 2017 10:37 am

Hi Jerry!

Just sending you this note for information you might want to put in the newsletter for C5 owners. In the past winters, I guess I have driven the Corvette more, and this year I have driven it and started occasionally, but I believe it was more of an old battery issue.

Battery was dead. I have not put my trickle charger on the battery being a C5 that does not have as many electronic gadgets that C6 and C7 have. I jumped the battery and Patti and I put the top down on one of the 80 degree March days for a 45 minute drive on west county backroads. I checked and tried to start the next morning, and dead. That evening I jumped it again and it started, but this time the warning came on the dash "Service Control Lock." Now the steering column was locked when the car was running. The code said "turn off car, remove key for 10 seconds." Did that. No good. Next call....to Jeff Craig.

Went and got a new battery as the sticker on the battery said 8/11....so the battery was in the car when I purchased it. Put in the new battery thinking this would do the trick. Nope. Still

the steering column is locked. After doing a little research on line, this is a GM problem for C5 Corvettes, however Tom Marlo indicated it happened on his C6. There were recalls for this problem, and I did check with Elco Chevrolet to see if the previous owner had the fix taken care of. It had been done.

So, now, I have to purchase some type of by-pass and have this installed just to unlock the steering column. This is a fix, but I believe the steering column will never lock again. So, the bottom line to all....don't be a dummy like me and not use your trickle charger.

Bob Kusky

Bob Kusky

US Paint Corporation

831 S. 21st Street

St. Louis, MO 63103

314 342 0268 O

314 616 5703 C

C5 Service Lock Issue <https://mail.aol.com/webmail-std/en-us/PrintMessage>

1

---

**Car Care from Ron Hagenow**

*Note from Paul Craig: Put your hand in a plastic sandwich bag and rub lightly with your fingers over the paint finish. You will be amazed and how much "stuff" is stuck to the finish.*

### Clay Bar Your Car

How many of you have ever clay barred your car? If you Google clay bar you will see all kinds of ways to do it. I did my Vette several years ago and recently decided to redo it again. Those of you who know me know that I don't take it out very often. But if you look at the before and after pictures of what the clay bar looked like, you might want to consider doing yours, even if it's a new one.

The purpose is to take off any dirt, tree sap, paint overspray or anything in general that doesn't come off with a wash and wax. The purpose is to get the surface as smooth as possible for the best shine.

It's very easy to do and doesn't take much time. I use detail spray as a lubricant. Make a few passes and if you see the clay bar is dirty, just fold it over and keep using a fresh side. I did my car in about 30-40 minutes. Follow it up with a good wax (C-Magic is my favorite).

I have a couple pictures of my car once I was finished. Not bad for almost 29 year old paint.

After using and new clay bar

Shine!

29



years old on May 31



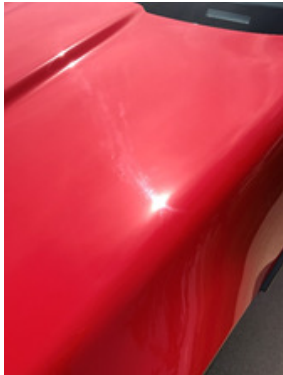

---

**Paul Craig sent this reminder from Corvette. Seems many folks are having trouble with the #%%\*&\*\*!! seat not working correctly.**



CORVETTE

## SETTING YOUR MEMORY SEAT PREFERENCES

### 2014 MODELS

#### TO STORE AN EXIT POSITION:

Important: Program your Exit position immediately in order to ensure you can enter and exit your Corvette comfortably.

1. Adjust the seat, steering column and side-mirror controls to find your desired Exit position (such as steering column positioned up and forward and seat moved back, while avoiding contact with the rear bulkhead behind the seat).
2. Press and release the "SET" button, located on the driver-side door.
3. Immediately press and hold the  ("EXIT") button until you hear a beep.

#### TO STORE A DRIVING POSITION:

Note: Preset driving positions can be stored for two drivers.

1. Adjust the seat, steering column and side mirrors to find your desired Driving position, making sure to avoid contact between the seat and rear bulkhead (behind the seat).
2. Press and release the "SET" button, located on the driver-side door.
3. Immediately press and hold the "1" or "2" button until you hear a beep.

### 2015 MODELS

#### TO STORE AN EXIT POSITION:

Important: Program your Exit position immediately in order to ensure you can enter and exit your Corvette comfortably.

1. Adjust the seat, steering column and side-mirror controls to find your desired Exit position (such as steering column positioned up and forward and seat moved back, while avoiding contact with the rear bulkhead behind the seat).
2. Press and release the "SET" button, located on the driver-side door. You should hear a single beep.
3. Immediately press and hold the  ("EXIT") button until you hear two beeps.

#### TO STORE A DRIVING POSITION:

Note: Preset driving positions can be stored for two drivers.

1. Adjust the seat, steering column and side mirrors to find your desired Driving position, making sure to avoid contact between the seat and rear bulkhead (behind the seat).
2. Press and release the "SET" button, located on the driver-side door. You should hear a single beep.
3. Immediately press and hold the "1" or "2" button until you hear two beeps.

### 2016 AND NEWER MODELS

#### TO STORE AN EXIT POSITION:

Important: Program your Exit position immediately in order to

#### TO STORE A DRIVING POSITION:

Note: Preset driving positions can be stored for two drivers.

---

### **Battery Care - low or dead battery**

One cause is keeping the key fob too close to the Corvette even in the house. The fob and the Vette keep talking to each other which runs down both batteries. Leave the fob in the house and go to the garage. Try to open the Vette door. If it opens, the fob storage spot is too close.

Some C6 and most C7 Corvettes come from the factory with a special battery charger which should be used at all times when the Vette is not driven on a regular basis. Circuits in the newer Corvettes run even if the ignition is off. Batteries may run down in a couple of weeks or sooner. Running the battery down to a low level will shorten the life a lot.

## BatteryMINDer® Model 1510: 12-Volt 1.5 Amp Maintenance Charger/Desulfator Including a 10 Year Warranty



**Price: \$64.95**

Availability: In Stock

\* Free Digital

**Voltmeter:**  
You must tick the Free Digital Voltmeter option.

**BatteryMINDer® Model 1510** features a SmarTECHnology™ plug 'n run 1.5 Amp battery charger/maintainer with full-time automatic high frequency pulse desulfator (not high voltage) that can help extend a battery's life up to 4 times its normal life. -20°C (-4°F) to 50°C (122°F), operating range. Ideal for charging, maintaining or recovering 12V flooded, sealed, maintenance-free, starter, deep-cycle, Optima brand sealed AGM, and marine batteries. Worldwide 100-240 VAC 50/60 Hz input. FCC compliant and California Energy Commission certified. The unit can maintain up to four 12 Volt batteries at one time when connected in parallel by using SmarTECHnology™ Y-Connectors ([part# 210AY](#)) or customer supplied 18-Gauge insulated wire.

The 1510 features all the same great capabilities of our most popular model, the 1500 but also includes the RTA-2415 Ring Terminal Assembly (a \$10 Value), BC-AA Battery Clips (a \$19.95 Value) & A 10 YEAR WARRANTY!

**For Corvettes without the factory charger, a good quality trickle charger is needed. This unit maintains the charge and cleans the plates for longer battery life and reliability. The battery in my 2004 Vette lasted 10 years.**

## Dead Battery

If the battery is dead, first find it. (No Joke - if you call a tow truck or AAA you will have to show them where the battery is.) If the battery is not under the hood, it will be under the rear floor on the passenger side. Pry up the floor mat and find the lid covering the battery.

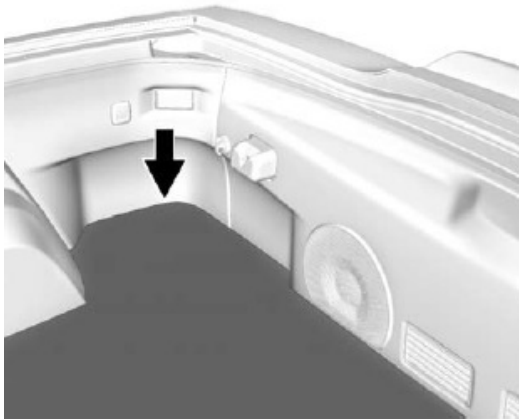

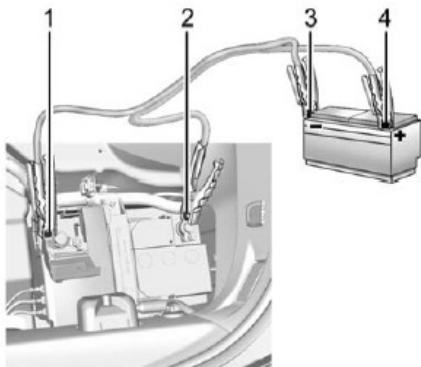
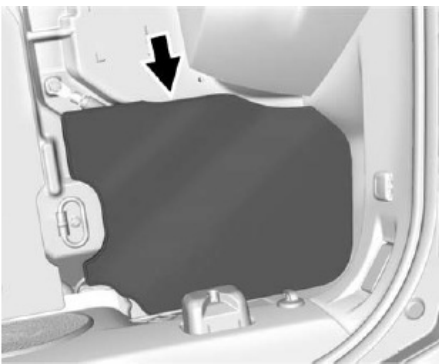

Connect the jumper cables: 1 to 4 + to + then 2 to 3 - to -. Be careful not to short out the clamps.  
Start the Vette.  
Remove the cables in the reverse order.

---

**Racing at Tire Rack test track - South Bend Indiana**

Good weather was welcome. A bit cold on Saturday - tire grip was scary.  
We have raced there in a sleet storm. Patty finishes a run and Peggy waits for a start.



---

**We welcome pictures, articles, event posters for publication**

**Email to:** [newsletter@stlcorvette.club](mailto:newsletter@stlcorvette.club)



---

**Many thanks to our sponsor:**

**Mark Gerecke 636-227-5333**

**Eric DeBruin 636-227-5333**



*Copyright © 2017 St. Louis Corvette Club, All rights reserved.  
Monthly Newsletter*

**Our mailing address is:**

St. Louis Corvette Club  
1009 Carole Lane  
Ballwin, Mo 63021

[Add us to your address book](#)

Want to change how you receive these emails?

You can [update your preferences](#) or [unsubscribe from this list](#)

